

Optimice[®] rack & caging technical specifications

Optimice rack

The Optimice exhaust vented carousel caging system offers a unique means of rodent housing in the animal care industry. This system is unmatched in space efficiency and its ability to house rodents in the best possible environmental conditions. The convection-assisted, low-velocity, one-pass airflow through each cage provides animals with the gentle ventilation necessary to ensure maximum comfort in an ideal, low-stress living and breeding environment. With no motors or blowers, Optimice rooms are free of noises, vibrations, and odors.

	Optimice Rack					
	Dimensions <i>Inches (mm)</i>				Weight <i>Pounds (kg)</i>	
	Depth	Width	Height	Auto-Water Height	Basic	Auto-Water
<i>Full rack with card holders</i>	40.5 (1029)	40.5 (1029)	76.9 (1953)	78.3 (1989)	613 (278)	659 (299)
<i>Empty rack</i>	33.8 (859)	39.8 (1011)			326 (148)	366 (166)

Rack Specifications

- Includes complete stainless steel rack assembly with reinforced polymer carousel, cages, casters, and two vent hose assemblies
- The rack frame is made of 304 stainless steel; the joint sections are welded and ground
- Includes 100 mouse cage assemblies with filters, feeders, cage card holders, cage cards, and water bottles (if so configured); cages and components available in polysulfone, polycarbonate or smoke polysulfone
- Two 3-inch (75 mm) diameter vent hoses mount near top center of rack with quick-disconnect fittings
- Rack assembly is mounted on stainless steel swivel casters with 4-inch (102 mm) diameter high-temperature ball bearing wheels; two casters come with locks
- Airflow requirements, per rack: 60 cubic feet per minute (1,700 liters per minute) recommended, 40 CFM (1,275 liters per minute) minimum; exhaust static pressure: 0.10 - 0.15 inches of water
- High-flow Reemay flat filter assemblies with integral face plates ensure uniform cage ventilation
- Auto-water racks include 10 manifolds (one per platter) that are plumbed to the water supply via each cage stations's water valve
- The auto-water manifolds are made of 316 stainless steel, and the tube diameter is 0.5 inches (12.7 mm)
- The Edstrom or SE Lab Group water valves are designed to connect with the manifold and supply water to each cage; the valves are made of 316 stainless steel
- Auto-water racks can be disinfected and sterilized without removing fixed components; the removable valve option features a valve that removes without special tools and can be steam sterilized

	Optimice Cage Dimensions <i>Inches (mm)</i>			
	Length	Width (front)	Width (rear)	Height
<i>Exterior</i>	14.3 (363)	11.34 (292)	3.83 (97)	6.1 (155)
<i>Interior</i>	12.5 (318)	11 (279)	3.5 (89)	5.06 (129)

Cage Specifications

Floor area: 75 square inches (484 square centimeters)

Capacity: Five 25g mice

Cage material: Polycarbonate or polysulfone (amber or smoke color)

Feeder: Polished stainless steel wire, 17 oz. (502 mL) capacity

Water bottle: 13.5 oz. (400 mL)

Optimice[®]

rack & caging technical specifications

Rack and Cage Options:

- Trough tunnel that provides enrichment for the animal population
- Edstrom or SE Lab Group automatic watering
- Polysulfone, smoke polysulfone, and polycarbonate cage assemblies
- High-capacity feeder: 30 oz. (890 mL) capacity
- J-feeder
- Cage dividers
- Rack light
- Rack options for external water bottle cages, external water bag cages, internal water bag holders
- Rack option for cages with feed ports
- Blockparty[®] to connect cages and harness their collective areas
- Red polycarbonate cages
- Red or opaque black water bottles

Optimice is a closed-system, barrier isolation caging system that provides unparalleled ease-of-use while maximizing population density and improving the welfare of both animals and caretakers.

Except where noted, rack and cage specifications above are also valid for C89300M/P/S, C89302M/P/S, and C89305M/P/S

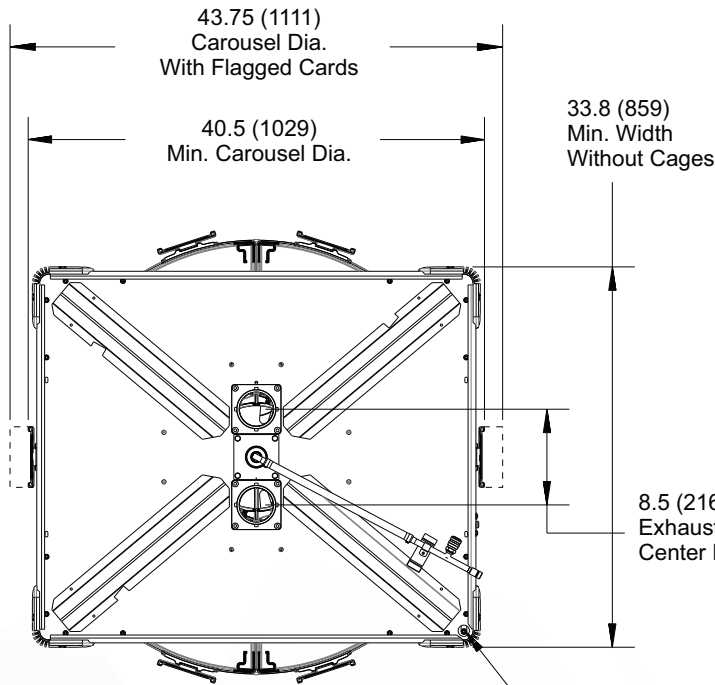

Weight, Basic	604 lbs (274 kg) with cages
Weight, Auto-water	650 lbs (295 kg) with cages
Auto-water Connection	Type M stainless steel QD
Ventilation, Minimum	45 CFM (1274 L/minute)
Ventilation, Recommended	60 CFM (1699 L/minute)
Ceiling Exhaust Drop	4-inch (100 mm) diameter ducting
Exhaust Hoses	Flexible 3-inch (75 mm) diameter x 72-inch (1830 mm) length

Automatic Watering
 Inlet Connection

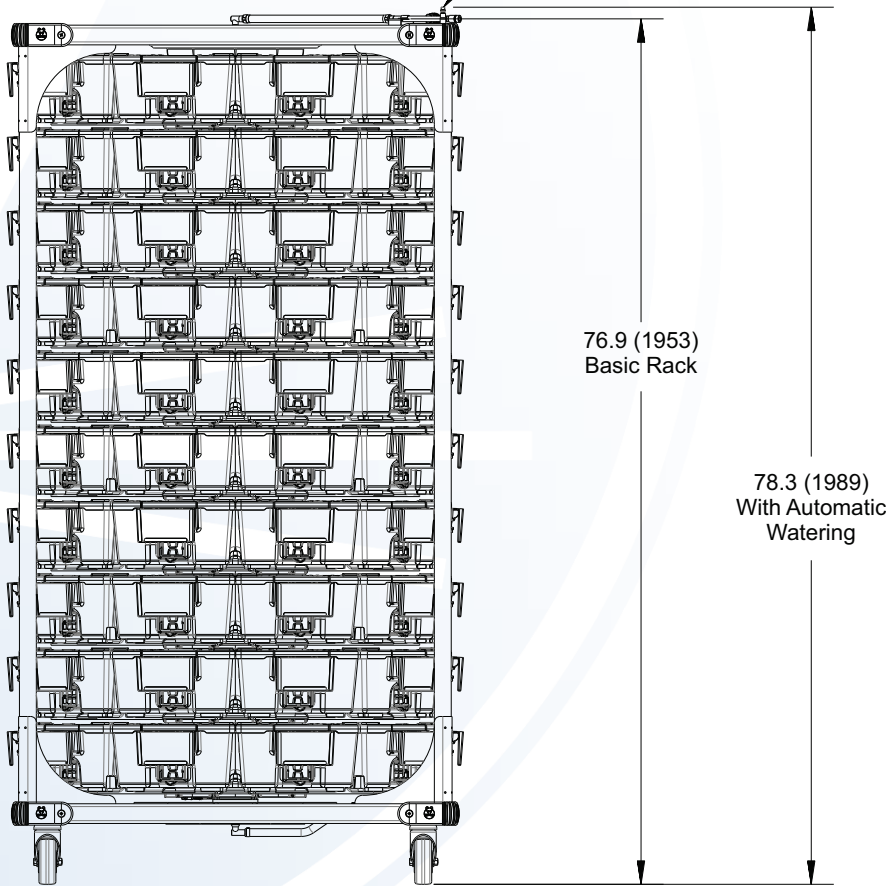

Dimensions in inches (millimeters)

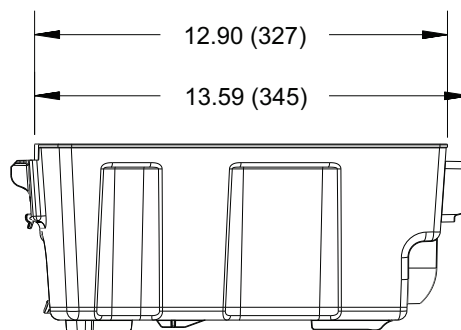
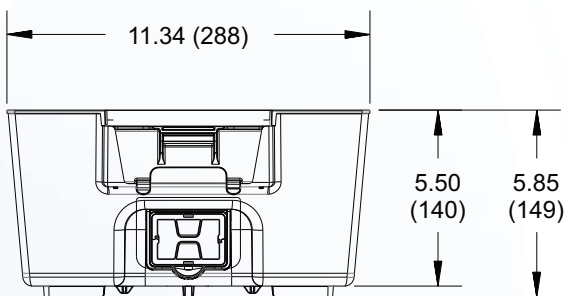
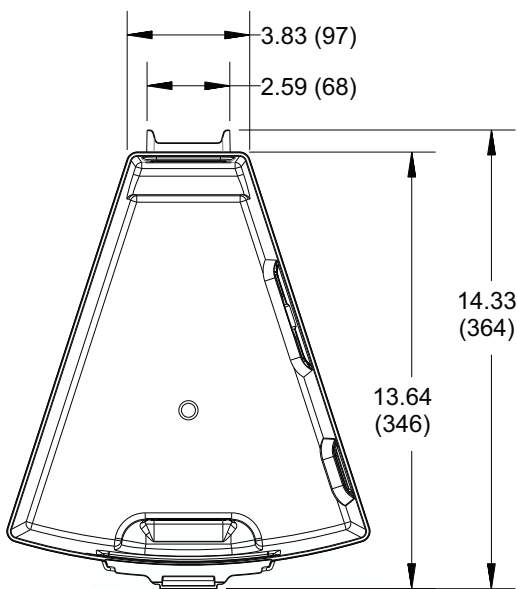

Cage Base
 Only

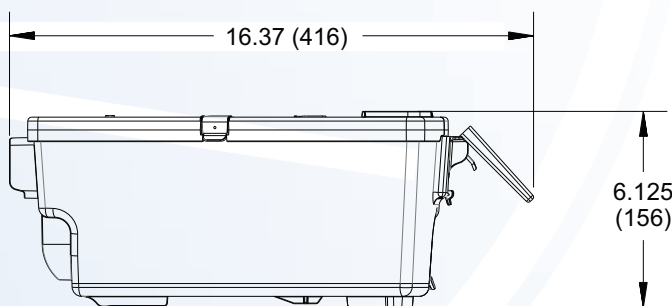

Card
 Flagged

Complete Cage
 Assembly

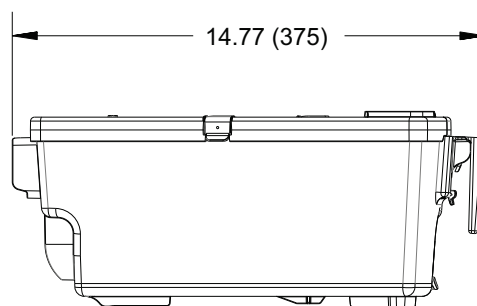

Card
 Unflagged

